

# TDK·Lambda



## **ZERO-UP** 200W/400W/800W Programmable DC Power Supplies

**Built-in RS-232 & RS-485 Interface  
with IEEE488 (GPIB) optional.**

- Constant Voltage/Constant Current
- Built-in RS-232 & RS-485 Interface
- An embedded Microprocessor controller
- Digital Encoder Knob
- Software Calibration
- Last Setting Memory
- Parallel Operation (Master/Slave) Active Current Sharing
- External Voltage or Resistance Programming
- Voltage up to 120V, Current up to 132A
- Active Power Factor Correction: 99%
- 85~265Vac Universal Input Voltage
- 19" Rack Mounted ATE and OEM
- Worldwide Safety Agency Approvals
- CE Mark for LVD and EMC Regulation



Control Flexibility for Worldwide Applications

### Product Line Up

Model	Output Voltage (VDC)	Output Current (A)	Output Power (W)
ZUP6-33	0 ~ 6 VDC	0 ~ 33	198
ZUP6-66		0 ~ 66	396
ZUP6-132		0 ~ 132	792
ZUP10-20	0 ~ 10VDC	0 ~ 20	200
ZUP10-40		0 ~ 40	400
ZUP10-80		0 ~ 80	800
ZUP20-10	0 ~ 20VDC	0 ~ 10	200
ZUP20-20		0 ~ 20	400
ZUP20-40		0 ~ 40	800
ZUP36-6	0 ~ 36VDC	0 ~ 6	216
ZUP36-12		0 ~ 12	432
ZUP36-24		0 ~ 24	864
ZUP60-3.5	0 ~ 60VDC	0 ~ 3.5	210
ZUP60-7		0 ~ 7	420
ZUP60-14		0 ~ 14	840
ZUP80-2.5	0 ~ 80VDC	0 ~ 2.5	200
ZUP80-5		0 ~ 5	400
ZUP120-1.8	0 ~ 120VDC	0 ~ 1.8	216
ZUP120-3.6		0 ~ 3.6	432

### Power Supply Identification / Accessories

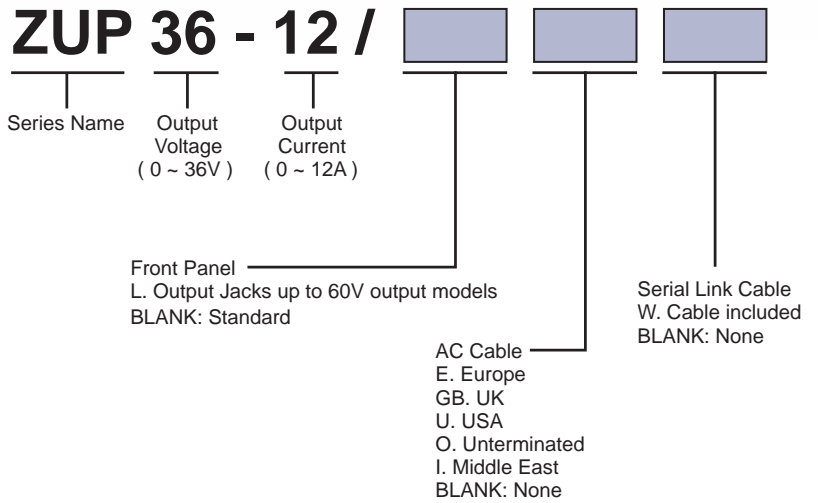

### Front Panel

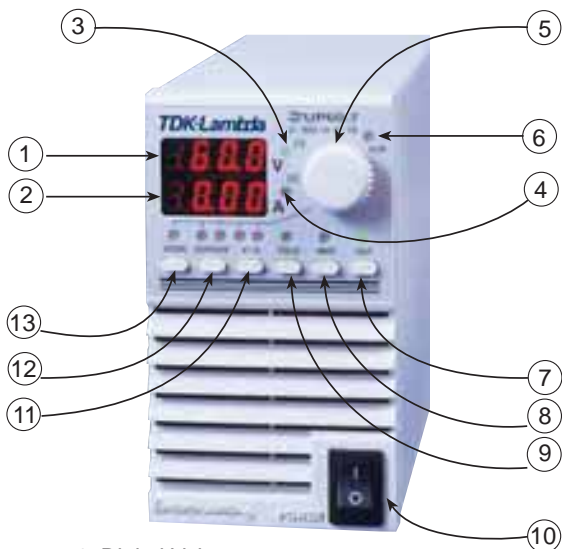

- Digital Voltmeter
- Digital Amperemeter
- Constant Voltage Mode Indicator
- Constant Current Mode Indicator
- Voltage/Current, OVP/UVP, Address Adjust
- Alarm ( OVP, OTP, FOLD )
- Output ON/OFF Control
- Local/Remote Select
- Foldback Protection Control
- AC Power Switch
- Voltage/Current Mode Control
- Overvoltage/Undervoltage Setting
- Address Setting

### Rear Panel

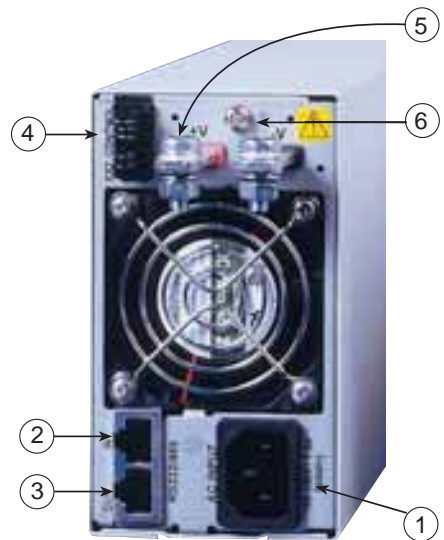

- IEC320 AC Input Connectors
- Remote IN Programming via RS-232/RS-485
- Remote OUT Via RS-485 Communications Chaining Power Supplies to Serial Communication Bus.
- External Analog Programming Control Connector
- Output Bus Bars (6V to 60V) model shown.  
80V to 120V models PHOENIX: PSC Plug Connectors
- Ground Thread

## ZUP Configurations

### BENCHTOP POWER SUPPLY

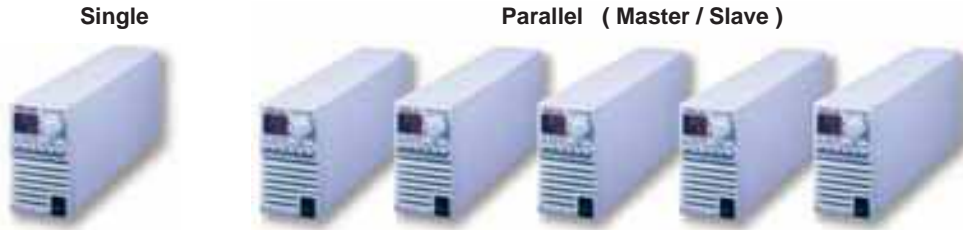

### PARALLEL OPERATION

Master - Slave method: Active current sharing up to 5 units.

### REMOTE PROGRAMMING VIA RS-232

Up to 31 ZUP units can be controlled via RS-232 interface.

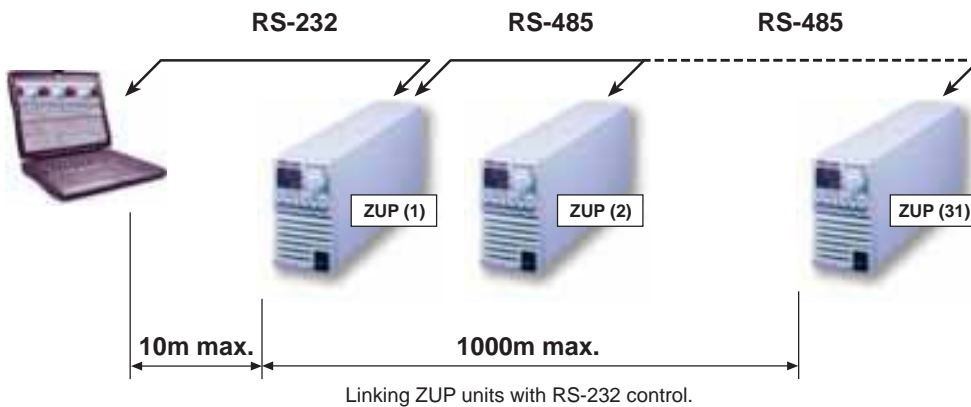

### REMOTE PROGRAMMING VIA RS-485

Up to 31 ZUP units can be controlled via RS-485 interface

For operation environments that require high noise immunity or long distance communication, it is recommended to use the built-in RS-485 interface.

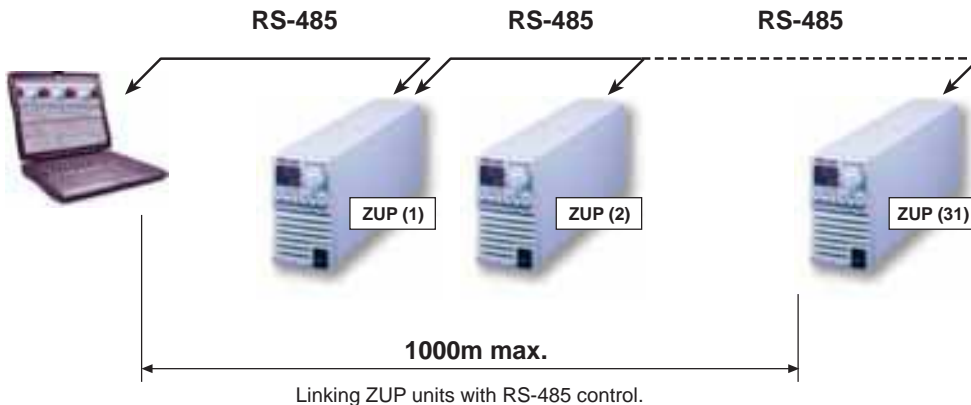

## Remote Programming Via GPIB.

### GPIB ↔ RS-485 CONTROLLER

The GP485A is a high performance serial to GPIB Interface

It enables a ZUP series with RS-485 port to be a Talker, Listener, or controller on the GPIB

- \* Controls up to 31 ZUP units through a single GPIB address.
- \* Conforms to all versions of the IEEE488 standard, including IEEE488.2.
- \* 19" racking possibility.
- \* Application software - LabView, LabWindows.

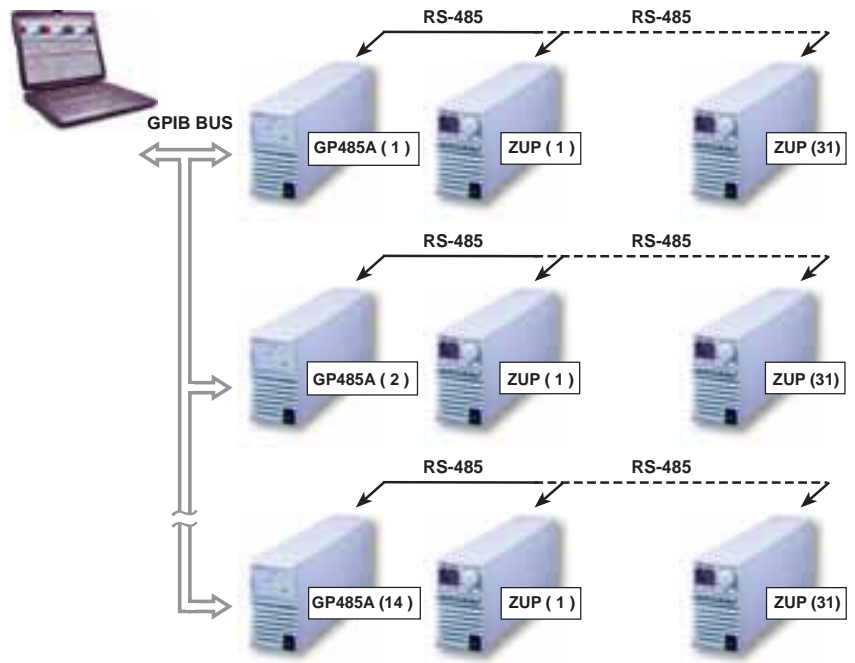

## Rack Mounted ATE and OEM up to 2.4KW

Six units can be assembled into 19-inch rack / 3U high to meet your configuration requirements

### Power Modules Table

Module Type	200W	400W	800W
0 ~ 6V	33A	66A	132A
0 ~ 10V	20A	40A	80A
0 ~ 20V	10A	20A	40A
0 ~ 36V	6A	12A	24A
0 ~ 60V	3.5A	7A	14A
0 ~ 80V	2.5A	5A	
0 ~ 120V	1.8A	3.6A	
19"rack width	1 / 6 width	1 / 6 width	2 / 6 width



### Zup Series Specifications

MODEL	ZUP6-33	ZUP6-66	ZUP6-132	ZUP10-20	ZUP10-40	ZUP10-80	ZUP20-10	ZUP20-20	ZUP20-40	ZUP36-6	ZUP36-12	ZUP36-24	ZUP60-3.5	ZUP60-7	ZUP60-14	ZUP80-2.5	ZUP80-5	ZUP120-3.6	ZUP120-3.6	
OUTPUT VOLTAGE (*1)	V	0-6	0-132	0-20	0-40	0-80	0-10	0-20	0-40	0-6	0-36	0-24	0-3.5	0-60	0-14	0-2.5	0-5	0-1.8	0-1.20	
OUTPUT CURRENT (*2)	A	0-33	0-66	0-132	0-40	0-80	0-10	0-20	0-40	0-6	0-12	0-24	0-3.5	0-7	0-14	0-2.5	0-5	0-1.8	0-3.6	
RATED OUTPUT POWER	W	198	396	792	200	400	200	400	800	216	432	864	210	420	840	200	400	216	432	
CONSTANT VOLTAGE	-	0.005%+2mV From No load to Full load, constant input voltage.																		
LOAD REGULATION	-	0.005%+1mV From 85-132VAC or 170-265VAC, constant load.																		
RMS RIPPLE (6Hz-1MHz Bandwidth)	mV	5	5	8	5	8	5	5	5	5	5	5	5	5	5	20	20	20	20	
RIPPLE (pk to pk) (20MHz Bandwidth)	mV	50	50	100	50	50	50	50	50	50	50	50	50	50	50	70	70	70	80	
RECOVERY TIME (*3)	ms	1			0.5			0.2			0.2			0.2		0.2		0.2		
TEMPERATURE COEFFICIENT	-	30ppm/°C from rated voltage following 30-minute warm-up.																		
TEMPERATURE DRIFT	-	0.01%+2mV Change in output over 8-hour interval under constant line, load and ambient temp following 30-minute warm-up.																		
UP PROGRAMMING RESPONSE TIME (*4)	ms	50	50	60	50	60	50	50	60	50	50	60	50	50	60	100	100	100	100	
DOWN PROGRAMMING FULL LOAD	ms	50	50	50	50	50	50	50	50	50	50	50	50	50	70	60	60	80	80	
RESPONSE TIME NO LOAD	ms	250			350			400			500			750		800		1000		
LOAD REGULATION (*5)	-	0.01%+5mA 0.01%+10mA 0.07%+10mA 0.01%+5mA 0.01%+5mA 0.01%+5mA 0.01%+5mA 0.01%+5mA 0.01%+5mA 0.01%+5mA 0.01%+5mA 0.01%+5mA 0.01%+5mA 0.01%+5mA 0.01%+5mA 0.01%+5mA 0.01%+5mA 0.01%+5mA 0.01%+5mA 0.01%+5mA																		
LINE REGULATION (*6)	-	0.01%+2mA 0.01%+2mA 0.01%+2mA 0.01%+2mA 0.01%+2mA 0.01%+2mA 0.01%+2mA 0.01%+2mA 0.01%+2mA 0.01%+2mA 0.01%+2mA 0.01%+2mA 0.01%+2mA 0.01%+2mA 0.01%+2mA 0.01%+2mA 0.01%+2mA 0.01%+2mA 0.01%+2mA 0.01%+2mA 0.01%+2mA																		
RMS RIPPLE (5Hz-1MHz Bandwidth)	mA	50	100	200	25	50	100	15	30	60	7.5	15	5	10	20	5	5	5	5	
TEMPERATURE COEFFICIENT	-	100ppm/°C from rated current following 30-minute warm-up.																		
TEMPERATURE DRIFT (*8)	-	0.02%+5mA 0.02%+5mA 0.02%+5mA 0.02%+5mA 0.02%+5mA 0.02%+5mA 0.02%+5mA 0.02%+5mA 0.02%+5mA 0.02%+5mA 0.02%+5mA 0.02%+5mA 0.02%+5mA 0.02%+5mA 0.02%+5mA 0.02%+5mA 0.02%+5mA 0.02%+5mA 0.02%+5mA 0.02%+5mA																		
RESOLUTION ACCURACY	-	Better than 0.02% of rated output voltage																		
RESOLUTION ACCURACY	-	Better than 0.03% of rated output current																		
CURRENT ACCURACY	-	0.4%+40mA																		
OVER VOLTAGE PROTECTION (*10)	V	0-7.5			0-13			0-24			0-40			0-66		0-88		0-132		
HOLD-UP TIME	-	20ms At 100V/200VAC, rated output voltage and output current.																		
VOLTAGE	-	3 digits (6v: 20v: 36v: 60v: 80v): 3.5 digits (10v: 120v) accuracy, 0.2% +/- 2 digits.																		
CURRENT	-	3.5 digits (132A): All others 3 digits, accuracy: 0.5% +/- 3 digits.																		
STATUS	-	CV/CC, Alarm, Fold, Local/Remote, On/Off.																		
OUTPUT PROTECTIONS	-	Over Voltage, Over Temperature, Feedback.																		
INPUT	-	85-265VAC Continuous, 47.63Hz.																		
INPUT VOLTAGE (*11)	A	3.0/1.5	5.6/2.7	11.2/5.4	2.9/1.4	5.6/2.7	11.2/5.4	2.9/1.4	5.6/2.7	11.2/5.4	2.9/1.4	5.6/2.7	2.9/1.4	5.6/2.7	11.2/5.4	2.6/1.3	4.9/2.4	2.9/1.4	5.3/2.6	
INPUT CURRENT (*12)	A	15/30 (*7)	15	30	15/30 (*7)	15	30	15/30 (*7)	15	30	15/30 (*7)	15	15/30 (*7)	15	30	15/30 (*7)	15	15/30 (*7)	15	
EFFICIENCY (*12)	%	69/72	74/77	74/77	73/77	79/82	77/81	74/78	79/83	79/82	76/80	80/84	75/79	80/84	80/84	76/82	83/87	76/82	82/86	
INPUT CURRENT HARMONICS	-	Complies with EN61000-3-2, Class A																		
POWER FACTOR (TYP)	-	0.99 at 100/200VAC, 100% load.																		
OPERATING TEMPERATURE	-	0 to 50 °C; 100% Load.																		
OPERATING HUMIDITY	-	30-90% RH (No dewdrop).																		
STORAGE TEMPERATURE	-	-20 to 70 °C																		
STORAGE HUMIDITY	-	10 - 95% RH (No dewdrop).																		
VIBRATION	-	10-55Hz, Amplitude (sweep 1 min) 2G, X, Y, Z. When mounted with mounting screws.																		
SHOCK	-	Less than 20G																		
WEIGHT	Kg	2.9	3.2	5.8	2.9	3.2	5.8	2.9	3.2	5.8	2.9	3.2	2.9	3.2	5.8	2.9	3.2	2.9	3.2	
SIZE (WHXHD)	mm	200W and 400W units: 70 x 124 x 350. 800W units: 140 x 124 x 350 (Refer to outline drawing)																		
OUTPUT ON/OFF	-	By TTL Signal or Dry Contact (Refer to instruction manual).																		
OUTPUT GOOD	-	Open collector (Refer to instruction manual).																		
OUTPUT VOLTAGE PROGRAMMING	-	By Voltage (0-4V) or by Resistance (0-4K) (Refer to instruction manual).																		
OUTPUT CURRENT PROGRAMMING	-	By Voltage (0-4V) or by Resistance (0-4K) (Refer to instruction manual).																		
REMOTE SENSING	-	Maximum 0.5V drop on each load wire for model up to 60V and 2V for the 80V, 120V models																		
COMMUNICATION INTERFACE	-	RS-232 and RS-485 Built-in, IEEE488 Optional																		
SAFETY STANDARDS	-	UL3111-1, EN61010-1																		
EMC STANDARDS	-	EN61326-1, IEC 61326-1, FCC part 15 (class A).																		
RADIATED EMI	-	EN55022-B, FCC-B, VCCI-B																		
SERIES OPERATION	-	Up to 2 units (Refer to instruction manual).																		
PARALLEL OPERATION	-	Master - Slave method: up to 5 units (Refer to instruction manual).																		
COOLING	-	Forced air by blower fan (Blower fan is mounted within unit).																		
WITHSTAND VOLTAGE	-	Input - Chassis, 2.0kVAC, 1 min. Input - Output, 3.0kVAC, 1 min. Output - GND...500VAC, 1 min.																		
ISOLATION RESISTANCE	-	More than 100MΩ at 25 °C and 70% R.H.																		

**NOTES:**

- Minimum voltage is guaranteed to maximum 0.2% of the rated output voltage.
- Minimum current is guaranteed to maximum 0.4% of the rated output current.
- Time for recovery to within +/-50mV against current change of 50% to 100%.
- From zero volts to full scale , resistive load and current setting at maximum.
- From no load to full load , constant input voltage.
- From 85-132VAC or 170-265VAC constant load.
- At cold start Ta=25 °C.
- Change in output over 8 hour interval constant line, load and ambient temperature following 30-minutes warm-up.
- Given for control of the output via the serial communication or via front panel controls.
- Inverter shut down method, manual reset (OVP will shut down output)
- For cases where conformance to various safety specs. (UL, IEC, etc.) are required, to be described as 100-240VAC (60/60Hz) on name plate.
- At 100/200Vac and Maximum Output Power.

## GP485A SPECIFICATIONS

The GP485A has all the software and logic required to implement the physical and electrical Specifications of the IEEE488 and RS-485 standards

Input Voltage /freq	Vac	85 ~ 265Vac continuous 47 ~ 63 Hz
Input consumption	W	5W
IEEE 488 Capability		SH1,AH1,T6,TE0,L4,LE0,SR1,RL0,PP1,DC1,DT0,C0,E1,E2
Indication LED's		Power /Ready ,Talk ,Listen ,SRQ
Baud rate	bps	Optional 300 , 600 ,1200 , 2400 , 4800 , 9600      Default :9600
Address		1 up to 30 can be set using an address switch
Operating temp	°C	0~ 50
Storage temp	°C	-20 ~ 70
Conducted emission		EN5022B,FCC-B
Radiated emission		EN5022A,FCC-A
Safety standards		UL3111-1 , EN61010-1
EMC standards		EN61326-1, IEC 61326-1, FCC part 15 (class A).
Withstand voltage		Input - Chassis...2.0kVAC 1min,    Input - Output...3.0kVac 1 min,    Output - Chassis...500VAC 1 min.
Vibration	G	10-55Hz, Amplitude (sweep 1 min ) 2G,    X, Y, Z, When mounted with mounting screws.
Size (WxHxD)	mm	70x124x350 (GP 485A has all the mechanical specifications & mounting hole as ZUP200W/400W units)
Weight	Kg	1.95

**Front Panel**

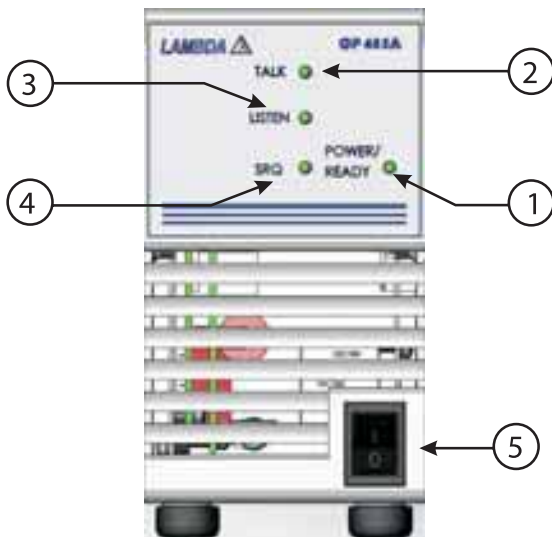

1. Power/Ready: Indicates that the power is "ON" and the self-test has passed successfully. The unit is ready to operate once the LED illuminates.
2. Talk: Indicates that the GP485A is addressed as a GPIB Talker.
3. Listen: Indicates that the GP485A is addressed as a GPIB Listener.
4. SRQ: Indicates that the GP485A signal line SRQ is asserted.
5. AC ON/OFF: Turns AC power On and Off.

**Rear Panel**

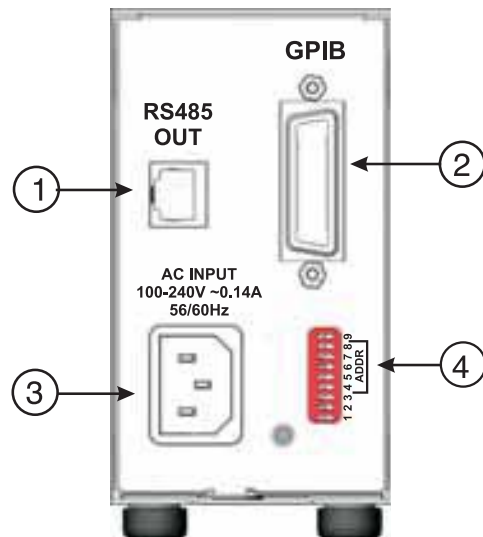

1. RS-485 OUT: EIA-568A shielded type connector, used for RS-485 communication with ZUP power supplies.
2. GPIB: Shielded 24-pin Champ female connector, with metric screwlock. Used for GPIB communication with the GPIB controller.
3. AC Input: IEC type appliance inlet.
4. Address setting Dip switch.

### Outline Drawings ZUP 200W/400W Units

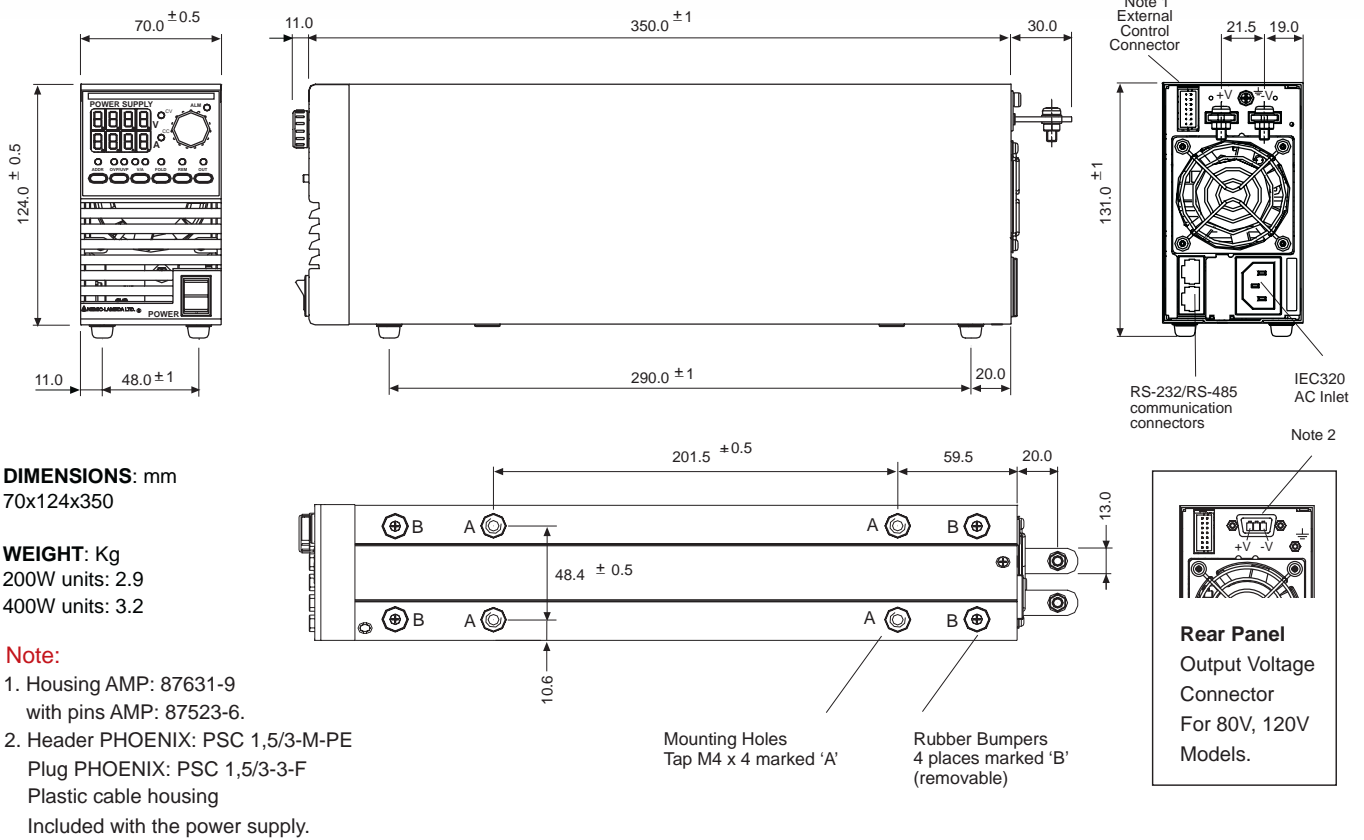

### Outline Drawings ZUP 800W Unit

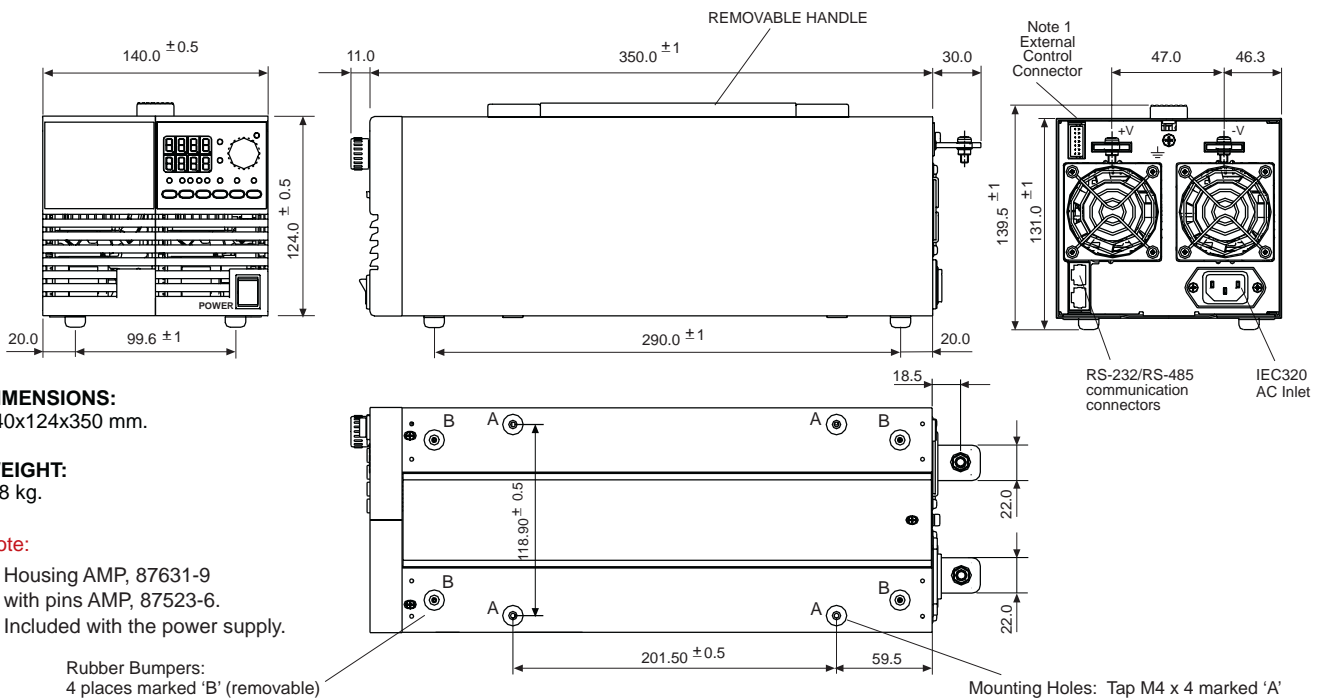

## Accessories

### 1. AC Cord Sets

Five optional cords are possible according to order:

Region	Europe	United Kingdom	Japan	Middle East	North America
Output Power	850W	850W	850W	850W	850W
AC Cords	10A/250Vac L=2m	10A/250Vac L=2m	13A/125Vac L=2m	10A/250Vac L=2m	13A/125Vac L=2m
Wall Plug	INT'L 7/VII	BS1363		SI-32	NEMA 5-15P
Power Supply Connector	IEC320-C13	IEC320-C13	IEC320-C13	IEC320-C13	IEC320-C13
Part Number	P/N: ZUP/E	P/N: ZUP/GB	P/N: ZUP/J	P/N: ZUP/I	P/N : ZUP/U

### 2. Communication Cable

RS-232/RS-485 cable is used to connect the power supply to the PC controller

Mode	RS-232	RS-485	RS-232	RS-485
PC Connector	DB-9F	DB-9F	DB-25F	DB-25F
Communication Cable	Shield Ground L=1m	Shield Ground L=1m	Shield Ground L=1m	Shield Ground L=1m
Power Supply Connector	EIA/TIA-568A (RJ-45)	EIA/TIA-568A (RJ-45)	EIA/TIA-568A (RJ-45)	EIA/TIA-568A (RJ-45)
P/N	ZUP/NC401	ZUP/NC402	ZUP/NC403	ZUP/NC404

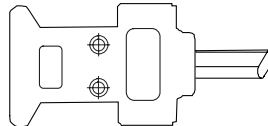
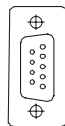
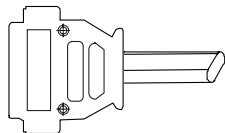
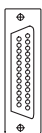

DB-25F (female connector)

DB-9F (female connector)

EIA/TIA (RJ-45)

### 3. ZUP serial link cable

Used to chain Power Supply to Power Supply from a serial communication bus

Mode	Communication cable	Power Supply Connector Remote IN /OUT	P/N
RS 485	Shield Ground , L=50cm	EIA /TIA -568 A (RJ-45)	ZUP/ W

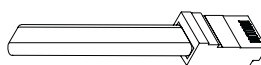
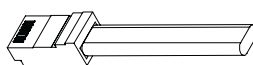

### Options ( 200W, 400W, 800W Models )

#### 1. FRONT PANEL OUTPUT JACKS

Up to 60V output models

P/N: ZUP / L

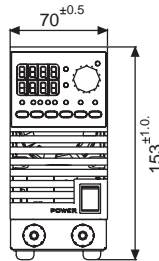

Outline Drawing: Physical Dimensions in mm.

ZUP 200W/400W Units: 70x153x405.9

ZUP 800W Units: 140x153x405.9

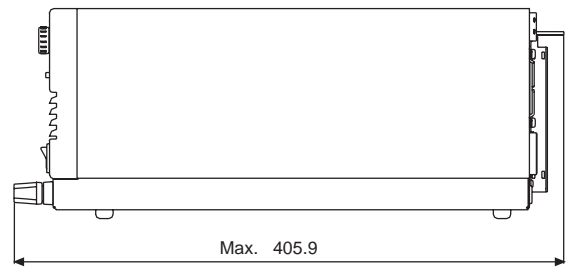

Up to 20A output current via front panel jacks.

#### 2. ZUP ASSEMBLIES

Dual Output Packing 200W/400W models

P/N: NL200

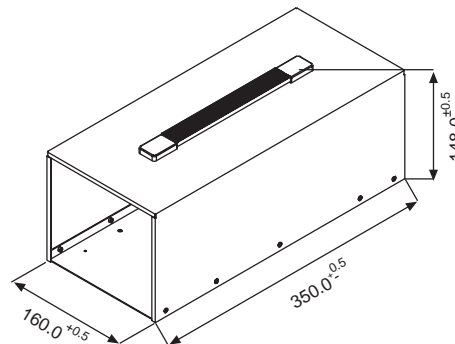

#### 3. 19" RACK MOUNTED ATE AND OEM UP TO 2.4 KW

Up to six power units can be assembled into a 19", 3U rack, kit P/N: NL100.

In cases where the entire rack is not occupied with power units, P/N: NL101 blank panels can be installed.

P/N: NL100

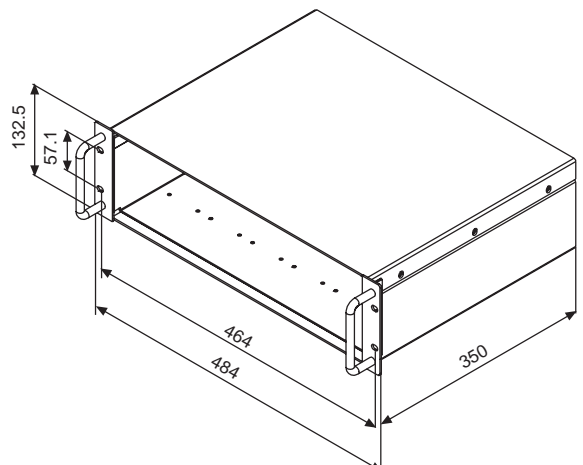

## Europe / North America

### NORTH AMERICA

Lambda Americas, Inc.  
3055 Del Sol Boulevard  
San Diego, CA 92154  
Tel: +1-800-LAMBDA-4  
Tel: +1-619-575-4400  
Fax: +1-619-429-1011  
www.lambdapower.com

Lambda Americas, Inc.  
405 Essex Rd. Neptune, NJ 07753  
Tel: +1-732-922-9300 Fax: +1-732-922-1441  
www.lambda-hp.com

### UK

Lambda UK  
Kingsley Avenue Ilfracombe, Devon  
EX 34 8ES United Kingdom  
Tel: +44-1271-856666 Fax: +44-1271-864894  
E-mail: powersolutions@lambda-europe.com  
www.lambda-gb.com

### FRANCE

Lambda SAS,  
ZAC des Delaches  
BP 1077 - Gometz le Chatel  
91940 LES ULIS  
Tel: +33 1 60 12 71 65  
Fax: +33 1 60 12 71 66  
www.lambda-f.com

### GERMANY

Lambda GmbH  
Karl-Bold-Str.40,  
D-77855 Achern, Germany  
Tel: +49-7841-666-0 Fax: +49-7841-500-0  
E-mail: info.germany@lambda-europe.com  
www.lambda-germany.com

### AUSTRIA

Lambda GmbH  
Aredstrasse 22,  
A - 2544 Leobersdorf, Austria  
Tel: +43 - 2256 - 655 84 Fax: +43 - 2256 - 645 12  
E-mail: info.germany@lambda-europe.com  
www.lambda-austria.com

### ITALY

Lambda S.r.l.  
Via dei Lavoratori 128/130  
IT 20092 Cinisello Balsamo (MI)  
Tel: +39-02-6129-3863 Fax: +39-02-6129-0900  
www.lambda-italy.com

### SCANDINAVIA

Lambda Scandinavia  
Rallarvägen 41  
SE-184 40 Akersberga  
Sweden  
Tel: +46 854 084 990  
Fax: +46 854 066 096  
E-mail: info@lambda-scandinavia.com  
www.lambda-scandinavia.com

## Asia / Far East / Middle East

### JAPAN

Densei Lambda KK,  
5F Dempa Bldg, 1-11-15 Higashigotanda,  
Shinagawa-Ku, Tokyo 141-0022, Japan  
Tel: +81 3 3447 4693  
Fax: +81 3 3447 4750  
www.densei-lambda.com

### CHINA

Shanghai Office of Wuxi Nemic-Lambda Electronic Co. Ltd.  
4F 2008 Hongmei Bldg, Hongmei Road,  
Cao He Jing Hi-Tech Park,  
Shanghai, China 200233  
Tel: +86-21-6485-0777 Fax: +86-21-6485-0666

Densei-Lambda K.K. Beijing Office  
Room 818 Office Tower One, Beijing Junefield Plaza,  
No.6 Xuanwumenwai St.,  
Xuanwu District, Beijing P.R.CHINA 100052  
Tel: +86-10-6310-4872 Fax: +86-10-6310-4874  
www.densei-lambda.com.cn

### HONG KONG

Densei Lambda Hong Kong Branch  
Room. 8, 27/F, Mega Trade Center  
1 Mei Wan St. Tsuen Wan, N.T. Hong Kong  
Tel: +852-2420-6693 Fax: +852-2420-3362  
www.densei-lambda.com

### KOREA

Densei Lambda K.K. Korea Branch  
6F Songok Bldg. 4-1 Soonae-Dong  
Pundang-Gu, Songnam-Shi Kyonggi-Do, 463-020 Korea  
Tel: +82-2-556-1171 Fax: +82-2-555-2706  
www.densei-lambda.co.kr

### MALAYSIA

Nemic-Lambda (M) SDN. BHD.  
No.7.3, 7th Floor, Jaya Shopping Center,  
Jalan Semangat Section 14, 46100  
Petaling Jaya Selangor, D.E, Malaysia  
Tel: +60-3-7957-8800 Fax: +60-3-7958-2400  
www.densei-lambda.com

### SINGAPORE

Nemic-Lambda (S) PTE Ltd.  
Blk 1008 Toa Payoh North # 06-01/08  
Singapore 318996  
Tel: +65-6251-7211 Fax: +65-6250-9171  
www.densei-lambda.com

### ISRAEL

Nemic Lambda Ltd.  
Sales Office:  
Kibbutz Givat Hashlosha Tel-Aviv 48800, Israel  
Tel: +972-3-9024-333 Fax: +972-3-9024-777  
Plant:  
POB 500 Karmiel Industrial Zone 20101, Israel  
Tel: +972-4-9887-491 Fax: +972- 4-9583-347  
E-mail: info@nemic.co.il  
www.nemic.co.il



**ZUP** ZERO-UP 200W/400W/800W  
Programmable DC Power Supplies

Power Control Electronic GmbH & Co. KG  
Bahnhofstr. 22  
D-87463 Dietmannsried

Tel: (+49) 08374-23260-0  
Fax: (+49) 08374-23260-99